

INDUSTRIAL

Aluminum Cutting

CNC Router Bits

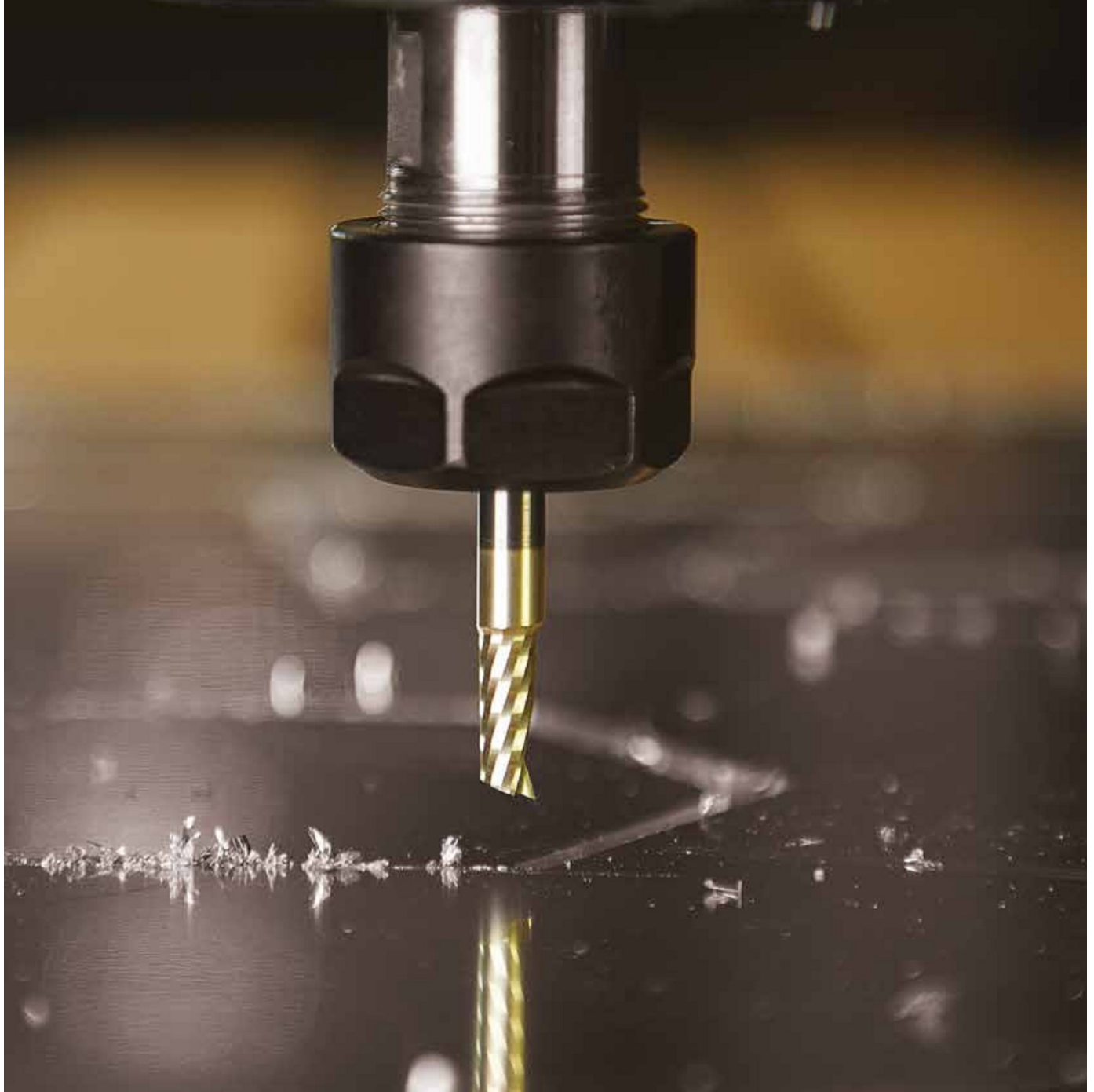

CNC ALUMINUM CUTTING SPIRAL 'O' FLUTE

Solid Carbide • Single Flute • Up-Cut & Down-Cut

Using the highest quality carbide, these bits have a special proprietary edge processing system featuring a super high polished cutting edge with a unique "mirror finish". The result is clean cuts, less chance for chip re-welding, a superior surface finish and longer tool life.

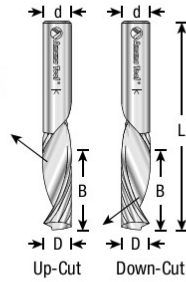
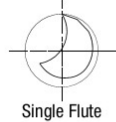

Benefits of Mirror Finish:

- Razor sharp cutting edge
- Effortless chip removal
- Helps prevent chip re-welding
- Extends tool life
- Exceptional cut quality



ØD	B	Ød	L	'Up-Cut' Tool No.	'Down-Cut' Tool No.
1/16	1/4	1/8	1-1/2	51470 † **	51770 †
3/32	1/4	1/8	2	51472 † **	—
1/8	1/4	1/8	1-1/2	51471 †	51771 †
1/8	1/4	1/4	2	51474	51772
1/8	5/16	1/8	1-1/2	51406 †	51506 †
1/8	5/16	1/4	1-1/2	51373	—
1/8	1/2	1/8	2	51459 †	51501 †
1/8	1/2	1/4	2	51454	51503
1/8	5/8	1/4	2-1/2	51482	—
1/8	3/4	1/4	2-1/2	51486	—
5/32	5/16	3/16	2	51473	—
3/16	3/8	3/16	1-1/2	51475	—
3/16	3/8	1/4	2	51477	51773
3/16	1/2	3/16	2	51374	—
3/16	1/2	1/4	2	51408	51508
3/16	5/8	3/16	2	51375	—
3/16	5/8	1/4	2	51478	—
3/16	7/8	1/4	2-1/2	51456	—
1/4	3/8	1/4	2	51479	51774
1/4	5/8	1/4	2	51402	51502
1/4	5/8	1/4	2-1/2	51401	—
1/4	3/4	1/4	2	51377	—
1/4	3/4	1/4	2-1/2	51480	51775
1/4	7/8	1/4	2-1/2	51458	—
1/4	1-1/4	1/4	3	51481	51776
1/4	1-1/2	1/4	3	51476	—
9/32	5/8	1/4	2	51451	—
5/16	9/16	5/16	2-1/2	51642	—
5/16	3/4	1/2	3	51483	—
21/64	3/4	1/2	3	51455	—
11/32	9/16	3/8	2-1/2	51457	—
3/8	3/4	3/8	3	51484	—
3/8	1	3/8	3	51378	—
3/8	1-1/8	3/8	3	51485	—
3/8	1-3/8	3/8	3-1/2	51643	—
1/2	1-1/8	1/2	2-1/2	51379	—
1/2	1-1/8	1/2	3-1/2	51487	—
1/2	1-3/8	1/2	3-1/2	51644	—
1/2	1-5/8	1/2	3-1/2	51489 *	—

† Router collet reducer RB-102 (1/4 to 1/8) available for 1/8 shank bits.
 * Special point for improved bottom finish. ** Not guaranteed due to size.
 ▲ **Warning:** Maximum RPM=35,000

Packs

Includes	Tool No.
51471, 46291, 51470, 51406 & 51459 (1/8 shank)	AMS-161 New
51402 & 51474 (1/4 shank)	AMS-194 New

Excellent For Cutting:

- Aluminum
- Aluminum 5052
- Aluminum 6061
- Aluminum Alloys
- Aluminum Composite Material (ACM)
- Aluminum Composite Panel (ACP)
- ALPOLIC® Copper Composite Material (CCM)
- Alucobond®
- Alupanel®
- Brass
- Copper
- Dibond®
- Durabond
- e-panel™
- Etalbond®
- Fomex® with Aluminum Face
- Gold
- Silver
- Titanium Composite Material (TCM)
- Wood

▲ **Warning:** Never attempt to cut ferrous metals with these bits. Inspect cut quality, adjust feed / speed accordingly. For optimal results and extended tool life use mist lubricant system or air cooling.

CNC feed and speed available online

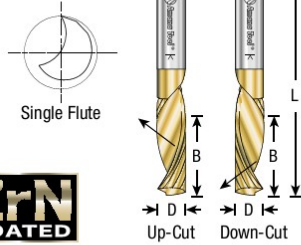

**ZrN
COATED**

Benefits of ZrN Coating:

- Creates a harder and tougher cutting edge
- Optimized flute geometry and low Total Indicated Runout (TIR) guarantees clean cuts, essentially eliminates sanding and reduces chatter when used with low TIR spindles
- Allows for a prolonged cutting edge life
- Helps to prevent the build-up of material in the flutes while cutting
- High flute volume supports high feed rates and chip loads



Set #AMS-160-Z

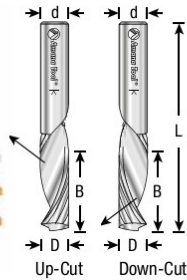

Excellent For Cutting:

- Aluminum
- Aluminum 6061
- Aluminum Alloys
- ACM
- ACP
- CCM
- Alucobond®
- Alupanel®
- Brass
- Copper
- Dibond®
- Durabond
- e-panel™
- Etalbond®
- Gold
- Silver
- TCM
- Wood



CNC ALUMINUM CUTTING SPIRAL 'O' FLUTE New

Solid Carbide • Single Flute • Up-Cut & Down-Cut

Produce super clean, smooth cuts in aluminum and non-ferrous metals. ZrN Coated.

For material cut list visit www.amanatool.com.



ØD	B	Ød	L	'Up-Cut' Tool No.	'Down-Cut' Tool No.
1/16	1/4	1/8	1-1/2	51470-Z † **	—
1/16	1/4	1/4	1-1/2	—	51488-Z **
3/32	1/4	1/8	2	51472-Z † **	—
3/32	1/4	1/4	2	51372-Z **	—
1/8	1/4	1/8	1-1/2	51471-Z †	—
1/8	1/4	1/4	2	51474-Z	—
1/8	5/16	1/8	1-1/2	51406-Z †	51506-Z †
1/8	5/16	1/4	1-1/2	51373-Z	51777-Z
1/8	1/2	1/8	2	51459-Z †	—
1/8	1/2	1/4	2	51454-Z	51503-Z
1/8	5/8	1/4	2-1/2	51482-Z	—
1/8	3/4	1/4	2-1/2	51486-Z	51778-Z
3/16	3/8	1/4	2	51477-Z	—
3/16	1/2	1/4	2	51408-Z	51508-Z
3/16	5/8	1/4	2	51478-Z	—
3/16	7/8	1/4	2-1/2	51456-Z	51779-Z
1/4	3/8	1/4	2	51479-Z	—
1/4	5/8	1/4	2	51402-Z	51502-Z
1/4	3/4	1/4	2	51377-Z	—
1/4	3/4	1/4	2	51480-Z	51786-Z
1/4	7/8	1/4	2-1/2	51458-Z	51775-Z
1/4	1-1/4	1/4	3	51481-Z	—
1/4	1-1/2	1/4	3	51476-Z	—
5/16	9/16	5/16	2-1/2	51642-Z	—

Sets

8-Pc Set includes 51470-Z, 51406-Z, 51474-Z, 51454-Z, 51408-Z, 51402-Z, 51502-Z, 51480-Z, RB-102 (2 included)

AMS-160-Z

† Router collet reducer RB-102 (1/4 to 1/8) available for 1/8 shank bits.

** Not guaranteed due to size.

▲ **Warning:** Maximum RPM=35,000

METRIC CNC ALUMINUM CUTTING SPIRAL 'O' FLUTE

Solid Carbide • Single Flute • Up & Down-Cut

Produce clean, smooth cuts in aluminum and non-ferrous metals. For material cut list visit www.amanatool.com



ØD	B	Ød	L	'Up-Cut' Tool No.	'Down-Cut' Tool No.
1.5mm	4mm	3mm	30mm	51370	—
2mm	6mm	6mm	64mm	57300	—
2.5mm	6mm	6mm	64mm	57301	—
3mm	8mm	3mm	30mm	51371	—
3mm	8mm	6mm	63mm	51490	—
3mm	12mm	6mm	50mm	—	57307
3mm	12mm	6mm	64mm	57302	—
4mm	8mm	4mm	66mm	57303	—
4mm	20mm	6mm	63mm	51492	—
5mm	16mm	6mm	63mm	51494	—
6mm	8mm	6mm	64mm	57304	—
6mm	20mm	6mm	64mm	51496	—
6mm	32mm	6mm	76mm	—	57308
8mm	25mm	8mm	64mm	51498	—
8mm	38mm	8mm	76mm	57305	—
10mm	30mm	10mm	76mm	57306	—

▲ **Warning:** Maximum RPM=35,000

▲ **Warning:** Never attempt to cut ferrous metals with these bits. Inspect cut quality, adjust feed / speed accordingly. For optimal results and extended tool life use mist lubricant system or air cooling.



CNC feed and speed available online

ALUMINUM CUTTING 'O' FLUTE New

Solid Carbide • Single 'O' Flute • Straight Grind

Combining "mirror-finish" fluting which insures the best of cutting edges possible in a solid carbide tool, along with a strong, straight-fluted design, these aggressive 'O' flute tools will give longer tool life.

Excellent For Cutting:

- Aluminum
- Fomex® with Aluminum Face
- Wood



ØD	B	Ød	L	Tool No.
1/8	1/2	1/8	2	43530
3/16	5/8	1/4	2	43532
1/4	3/4	1/4	2-1/2	43534
1/2	1	1/2	3	43539

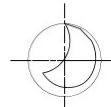
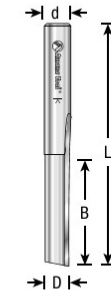

Single Flute



30° AND 45° ENGRAVING New

1/4" Shank • Solid Carbide • Single Flute

For extra-fine carving and lettering details for signmaking in aluminum, wood, plastic and solid surface materials. ZrN coated.

30° Single Flute

t = tip width	B	Ød	L	Tool No.
0.005	0.440	1/4	2-1/4	45771-Z

45° Single Flute

t = tip width	B	Ød	L	Tool No.
0.025	0.272	1/4	2	45622-Z

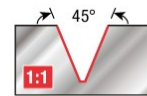
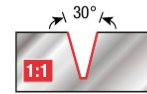

8-PC. CNC ALUMINUM CUTTING SPIRAL 'O' FLUTE

1/4" Shank • Solid Carbide Spiral Router Bit Collection

Excellent For Cutting:

- Aluminum
- Aluminum Alloys
- ACM
- ACP
- Alucobond®
- Alupanel®
- Brass/Bronze
- CCM
- Copper
- Dibond®
- Durabond
- e-panel™
- Etalbond®
- Fomex® with Aluminum Face
- Silver/Gold
- TCM
- Wood



CNC feed and speed available online



Set #AMS-160 Includes:

51474, 51454, 51408, 51402, 51480, 51481, 51508 & 51502

18-PC. CNC ADVANCED ALUMINUM CUTTING

1/4" Shank • Solid Carbide Router Bit Collection

Excellent For Cutting:

- Aluminum
- Aluminum Alloys
- ACM
- Alucobond®
- Alupanel®
- Brass/Bronze
- Carbon Fiber
- CCM
- Composites
- Copper
- Dibond®
- Fiberglass
- Fomex® with Aluminum Face
- Graphite
- HDF/MDF
- HDU
- Laminate
- Phenolic Composites
- Plastic/Acrylic
- Plywood
- Silver/Gold
- Sign Foam
- TCM
- Wood



CNC feed and speed available online



Set #AMS-162 Includes:

51474, 51454, 51477, 51408, 51478, 51479, 51402, 51480, 51502, 45762, 46280, 46282, 51452, 51464, 51460 & RC-1075

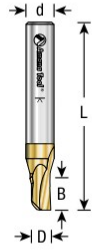

SOFT ALUMINUM CUTTING

Solid Carbide • Single Flute • Up-Cut

Solid carbide single flute aluminum router bits, Zirconium Nitride (ZrN) coated, are especially designed to cut soft grades of aluminum sheet, 3003 grade to achieve a satisfactory finished edge. Also good for cutting brass, bronze, copper, gold and silver.



ØD	B	Ød	L	Max RPM	Tool No.
3/16	1/4	1/4	2	28,000	51450
1/4	1/4	1/4	2	28,000	51452

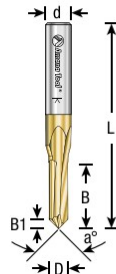

90° V-GROOVE & ENGRAVING

Solid Carbide • 2 Flute

Designed for beveling or V-Grooving 90°. For material cut list visit www.amanatool.com.



a°	ØD	B	B1	Ød	L	Tool No.
90°	1/8	5/8	1/16	1/8	2	45608
90°	1/8	5/8	1/16	1/4	2-1/4	45609
90°	3/16	5/8	3/32	1/4	2-1/4	45610
90°	1/4	3/4	1/8	1/4	2-1/4	45612
90°	3/8	3/4	3/16	3/8	2-1/2	45614

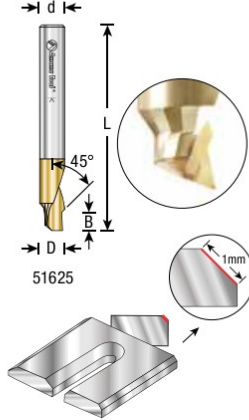
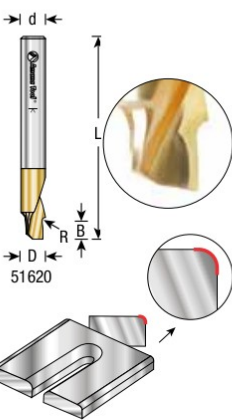

RADIUS & CHAMFER EDGE NON-FERROUS CUTTING END MILL

Solid Carbide • Single Flute • Up-Cut

By combining the up-cut design along with the common 3/32" convext radius or 45° chamfer, you can maximize your efficiency by routing one single pass.

Excellent For Cutting:

- Aluminum
- Brass
- Copper
- Non-Ferrous Metals



ØD	B	R	Ød	L	Type	Tool No.
3/16	3/32	3/64	1/4	2	Radius	51620
3/16	1/8	3/64	1/4	2	Radius	51622
3/16	3/32	—	1/4	2	Chamfer	51625
3/16	1/8	—	1/4	2	Chamfer	51627

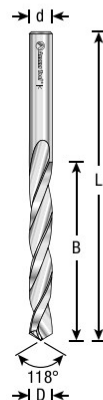

CNC 4 FACET DRILLS

Solid Carbide • 118° Drill Point

Drill non-ferrous, iron and a variety of steels. See website for full material list. 2-flute design.



ØD	B	Ød	L	Tool No.
1/8	1-1/4	1/8	2-1/4	SCFD-100 †
5/32	1-3/8	5/32	2-1/2	SCFD-102
3/16	1-5/8	3/16	2-3/4	SCFD-104
7/32	1-3/4	7/32	3	SCFD-106
1/4	2	1/4	3-1/4	SCFD-108
5/16	2-3/8	5/16	4	SCFD-112
3/8	2-3/4	3/8	4-1/4	SCFD-116
1/2	3	1/2	4-3/4	SCFD-124
9/16	4	9/16	6	SCFD-126
3/4	4	3/4	6	SCFD-128

† Router collet reducer RB-102 (1/4 to 1/8) available for 1/8 shank drills.

More sizes and types (Letter, Number & Metric) available upon request.



CNC feed and speed available online

HIGH SPEED STEEL (HSS) FOR ALUMINUM

Up-Cut & Down-Cut



Single Flute: for routing materials where speed and easy chip removal are desired.
Double Flute: provides a smoother finish than single flute when grooving, slotting.

ØD	B	Ød	Flute	L	'Up-Cut' Tool No.	'Down-Cut' Tool No.
1/8	3/8	1/4	1	2-5/8	HSS1620	—
3/16	5/8	1/4	1	2-7/8	HSS1621	—
1/4	5/8	1/4	1	2-3/4	HSS1622	—
1/4	3/4	1/4	1	2-3/4	—	HSS1628
1/4	3/4	1/2	1	3-1/4	HSS1623	—
1/4	1	1/4	1	3	—	HSS1629
5/16	3/4	1/2	1	3-1/4	HSS1624 <i>New</i>	—
5/16	1	1/2	1	3-1/2	HSS1625 <i>New</i>	—
21/64	3/4	1/2	1	3-1/4	HSS1626 <i>New</i>	—
3/8	1	1/2	1	3-1/2	HSS1627 <i>New</i>	—
1/8	5/16	1/4	2	2-5/8	—	HSS1650
1/8	3/8	1/4	2	2-5/8	HSS1630	—
3/16	5/8	1/4	2	2-7/8	HSS1631 <i>New</i>	HSS1651 <i>New</i>
7/32	7/8	1/4	2	3	HSS1632 <i>New</i>	—
1/4	5/8	1/4	2	2-3/4	HSS1633	HSS1652 <i>New</i>
1/4	3/4	1/4	2	2-3/4	HSS1634	HSS1653
1/4	3/4	1/2	2	3-1/4	HSS1635	HSS1654
1/4	1	1/4	2	3	HSS1636	HSS1655 <i>New</i>
1/4	1	1/4	2	3-1/4	—	HSS1656
5/16	3/4	1/2	2	3-1/4	HSS1637	HSS1657 <i>New</i>
5/16	3/4	3/8	2	3	HSS1638 <i>New</i>	—
5/16	1	5/16	2	3	HSS1639 <i>New</i>	HSS1658 <i>New</i>
5/16	1	1/2	2	3-1/2	HSS1640 <i>New</i>	HSS1659
3/8	1	3/8	2	3	HSS1641	—
3/8	1	1/2	2	3-1/2	HSS1642 <i>New</i>	HSS1660 <i>New</i>
3/8	1-1/4	1/2	2	3-3/4	HSS1643 <i>New</i>	—
1/2	1-1/4	1/2	2	3-1/4	HSS1644	HSS1661
1/2	1-1/2	1/2	2	3-1/2	HSS1645	HSS1662 <i>New</i>
3/4	1-1/4	1/2	2	3-1/4	HSS1646 <i>New</i>	HSS1663 <i>New</i>

CNC feed and speed available online

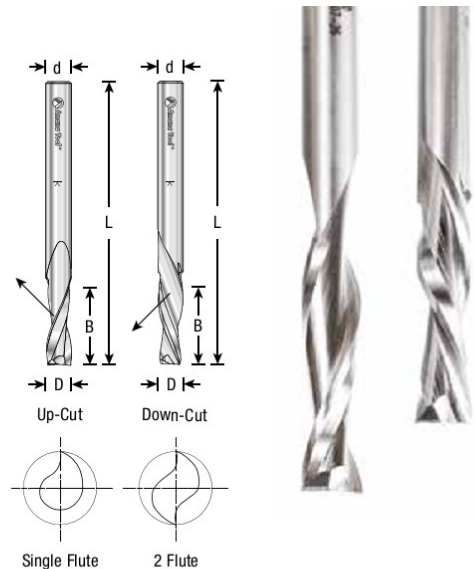

Excellent For Cutting:

- | | |
|--------------------|---------------------|
| 1 Flute (Up-Cut) | 2 Flute (Down-Cut) |
| Aluminum Plate | Aluminum Extrusions |
| Natural Wood Plate | Natural Wood Plate |
| 1 Flute (Down-Cut) | 2 Flute (Up-Cut) |
| Aluminum Plate | Aluminum Plate |
| | Aluminum Block |
| | Natural Wood Plate |

Down-cut tools are recommended when chip removal is directed down to protect the finish of the top of the material that has been cut.

CNC NON-FERROUS FACE MILLING

Insert Carbide • 4 Flute



The replaceable tips end mill/router bit tool body made from alloy steel with 4 solid carbide cutting inserts for maximum feed and stability are specially made for CNC and milling machines. Each solid carbide tip has 4 cutting rounded corners that can be rotated.

- Excellent For Cutting:**
- Aluminum, Bronze & Copper
 - Fomex® with Aluminum Face

- Applications:**
- Milling / Surfacing / Facing
 - Shouldering / Rabbeting
 - Slotting / Grooving

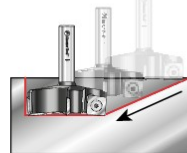

Use "Ramp Down" Technique.

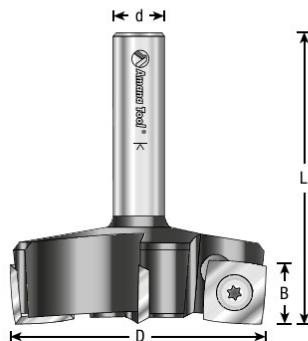

ØD	B	Ød	L	Max RPM	Repl. Knife	Tool No.
2-31/64	15mm	1/2	2-53/64	8,000	RCK-458	RC-3400

Maximum recommended material depth in one pass 1/32" (1.0mm).

CNC feed and speed available online



Milling / Surfacing / Facing



Shouldering / Rabbeting



Slotting / Grooving



INDUSTRIAL

ACM

Aluminum Composite Material
Router Bits

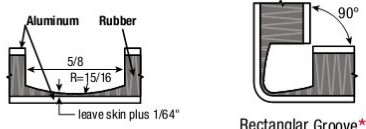
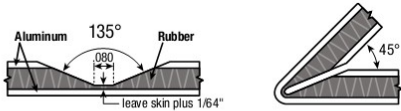
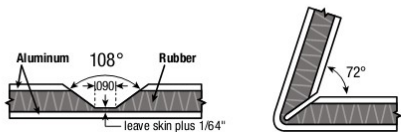
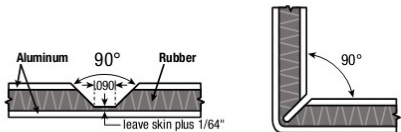
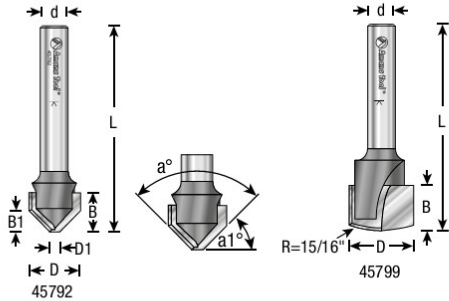

Rectangular Groove*

* For rectangular grooves in thicker material like Alucore®

ACM DOUBLE EDGE FOLDING

Carbide Tipped • V-Groove

Designed for shaping Aluminum Composite (sandwich) Materials with 90°, 108°, 135°, and 155° angle V-grooves with flat bottom. Ideal for wall panel fabrication. Widely used for cladding many diverse exterior and interior applications. The long lasting durability of the material makes it an excellent choice for buildings, signage, displays, etc. Routing V-shaped grooves, whereby the aluminum cover and a part of the polyethylene core is removed, allows for folding the remaining material.

For Scoring Aluminum Composite Materials Including:

- Aluminum, Clay, Zinc & Wood Composite Panels
- Aluminum Composite Material (ACM)
- Aluminum Composite Panel (ACP)
- ALPOLIC® Copper Composite Material (CCM)
- Alucobond®
- Alupanel®
- Dibond®
- Durabond
- e-panel™
- Etalbond®
- PE and FR Cores
- Phenolics
- Plastic/Acrylic
- Plexiglas®
- Titanium Composite Material (TCM)
- Wood



a°	a1°	ØD	ØD1	B	B1	Ød	L	Tool No.
90°	45°	1/2	0.090 (2.3mm)	3/8	13/64	1/4	2	45792
90°	45°	1/2	0.090 (2.3mm)	3/8	13/64	6mm	2	45792-M
90°	45°	1/2	0.090 (2.3mm)	3/8	13/64	1/2	2	45794
90°	45°	3/4	0.118 (3.0mm)	17/32	5/16	1/4	2-1/8	45793
108°	36°	1/2	0.090 (2.3mm)	3/8	5/32	1/4	2	45795
108°	36°	1/2	0.090 (2.3mm)	3/8	5/32	1/2	2-3/64	45797
108°	36°	1/2	0.090 (2.3mm)	3/8	5/32	1/2	3	45736
135°	22.5°	3/4	0.078 (2.0mm)	1/2	9/64	1/4	2-1/4	45798
135°	22.5°	3/4	0.078 (2.0mm)	1/2	1/8	1/2	2-1/2	45791
155°	12.5°	3/4	0.118 (3.0mm)	1/2	1/8	1/2	2-1/2	45737 New
—	—	5/8	—	7/16	—	1/4	2	45799 *

Packs

Includes 45792, 45795 & 45798 (1/4 shank)	AMS-140
Includes 45794, 45797 & 45791 (1/2 shank)	AMS-147



PCD Polycrystalline Diamond

Excellent cutting surfaces and extremely long life. Good for scoring above materials. Also optimal for panels with mineral core which may meet fire regulations.

a°	a1°	ØD	ØD1	B	B1	Ød	L	Tool No.
90°	45°	1/2	0.090 (2.3mm)	3/8	13/64	1/4	2	DRB-450



CNC feed and speed available online



ACM DOUBLE EDGE FOLDING

Carbide (Brazed to Steel Shank) V-Groove

Designed For Scoring Aluminum Composite Materials

For material cut list visit www.amanatool.com.



a°	a1°	ØD	ØD1	B	B1	Ød	L	Tool No.
90°	45°	1/2	0.090 (2.3mm)	3/8	13/64	1/4	2-1/8	45745
90°	45°	1/2	0.090 (2.3mm)	3/8	13/64	1/2	2-3/8	45747
108°	36°	1/2	0.090 (2.3mm)	3/8	5/32	1/4	2-1/8	45781
108°	36°	1/2	0.090 (2.3mm)	3/8	5/32	1/2	2-3/8	45785
135°	22.5°	3/4	0.078 (2.0mm)	1/2	1/8	1/4	2-1/4	45741
135°	22.5°	3/4	0.078 (2.0mm)	1/2	1/8	1/2	2-1/2	45743

Sets

- 3-Pc Set includes 45745 (90°), 45781 (108°) & 45741 (135°) (1/4 Shank) **AMS-218 New.**
- 3-Pc Set includes 45745 (90°), 45795 (108°) & 51402-Z (1/4 Shank) **AMS-213 New.**
- 3-Pc Set includes 45747 (90°), 45785 (108°) & 45743 (135°) (1/2 Shank) **AMS-219 New.**

Tools are manufactured with high balance, that allows them to run up to 60,000 RPM. Adjust your chip load and feed rate accordingly. See page 8 for cut illustrations.

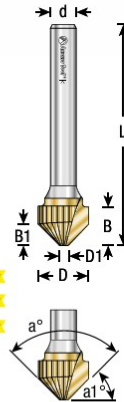

Benefits of ZrN Coating:

- Creates a harder and tougher cutting edge
- Allows for a prolonged cutting edge life
- Helps to prevent the build-up of material in the flutes while cutting



AITiN COATED BITS

SCM DOUBLE EDGE FOLDING

Carbide (Brazed to Steel Shank) V-Groove

Special Amana-grade carbide provides much longer tool life especially compared to carbide tipped tooling.

For Scoring Steel and Titanium Composite Materials:

- Metal Composite Material (MCM)
- Steel Composite Material (SCM)
- Titanium Composite Material (TCM)



a°	a1°	ØD	ØD1	B	B1	Ød	L	Tool No.
90°	45°	1/2	0.090 (2.3mm)	3/8	13/64	1/4	2-1/8	45762
90°	45°	1/2	0.090 (2.3mm)	3/8	13/64	1/2	2-3/8	45778
108°	36°	1/2	0.090 (2.3mm)	3/8	5/32	1/4	2-1/8	45749

See previous page for cut illustrations.

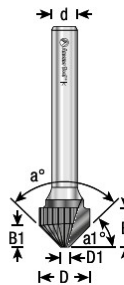

Benefits of AITiN Coating:

- Extra wear resistance
- Allows for faster feed & speed rates
- Cutting edge protected from wear
- Better chip evacuation
- Superior cut quality & extended tool life



CNC ACM DOUBLE EDGE FOLDING

Insert Carbide • V-Groove for Shaping Composite Material Panels

Special Amana-grade insert carbide provides much longer tool life especially compared to carbide tipped tooling.

For Scoring Aluminum Composite Materials Including:

- Aluminum, Clay, Zinc & Wood Composite Panels
- ACM
- ACP
- CCM
- Alucobond®
- Alupanel®
- Dibond®
- Durabond
- e-panel™
- Etalbond®
- PE and FR Cores
- Phenolics
- Plastic/Acrylic
- Plexiglas®
- SCM
- TCM
- Wood



ØD	ØD1	a°	a1°	B	B1	Flute	Ød	L	Repl. Knives	Tool No.
43/64	0.090	90°	45°	19/64	—	2	1/4	2-9/32	RCK-456	RC-45716
43/64	0.090	90°	45°	19/64	—	2	1/2	2-9/32	RCK-456	RC-45714
1-1/2	0.090	90°	45°	45/64	1	1	1/2	3	RCK-442	RC-1172
1-47/64	2mm	110°	35°	37/64	1	1	1/2	3-5/32	RCK-444	RC-1175
2-1/8	3mm	130°	25°	15/32	1-7/64	2	1/2	3	RCK-446	RC-1177

Optional knives for RC-1175: General Purpose #RCK-119; MDF #RCK-352.

Optional knives for RC-1177: General Purpose #RCK-136; MDF #RCK-353.

Visit www.amanatool.com for technical details and a complete list of replacement parts.

See page 8 for cut illustrations.

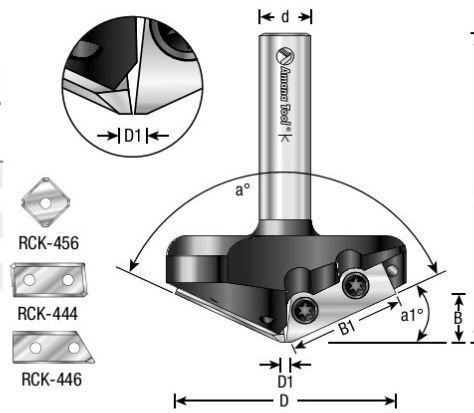

Set **AMS-151**
See page 72



ACM Saw Blades
See page 338-339



CNC feed and speed available online



INVECTRA™

ALUMINUM LAMINATE TRIM

Solid Carbide Spiral • 2 Flute with Ball Bearing Guide

Designed and tested for trimming all decorative aluminum laminates manufactured by Formica®, Advanced Technology Inc. (ATI™), DecoMetal® and many others. Engineered from our exclusive carbide grade designed specifically for cutting both aluminum laminates and wood-based substrate materials. Each bit is fitted with a steel bearing guide that enables users to trim laminate materials flush, allowing you to perform any metal trim job to perfection! Not for use on stainless steel.

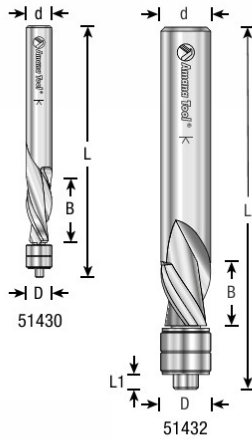

OD	B	Od	L	L1	Tool No.
1/4	5/8	1/4	2-1/2	—	51430* ▲ ²⁸
1/2	5/8	1/2	3-1/2	5/32	51432* ▲ ¹⁴

#51430 Replacement bearing #47723 (2), lock ring #47779.

#51432 Replacement bearing #47701 (2), lock ring #47752, replacement washer #67053.

* Except material: Formica® #2178

▲¹⁴ Warning: Maximum RPM ▲¹⁴ = 14,000; ▲²⁸ = 28,000



With Invectra™ router bits, kitchen fabricators, remodelers and construction workers can perform any kind of cut and trim job in aluminum laminates.

ALUMINUM CUTTING FLUSH TRIM SPIRAL

Solid Carbide • 2 Flute with Ball Bearing Guide • Up & Down-Cut

This flush trim router bit was designed to eject chips up for clean cuts in aluminum and ACM materials. Perfect for routing aluminum using a template. Features a special carbide grade to perform high-quality cuts in aluminum.



OD	B	Od	L	'Up-Cut' Tool No.	'Down-Cut' Tool No.
1/4	1/2	1/4	3	51422	51522
1/4	1-1/4	1/4	3-1/2	51420	51520

Replacement parts: Bearing #47723 (2); Snap Ring #47779.

45° ALUMINUM & PLASTIC CUTTING BEVEL TRIM

Carbide Tipped • 2 Flute

For bevel trimming in aluminum and plastic with a standard router. The solid construction reduces vibration for the smoothest cut possible with a two flute bit.

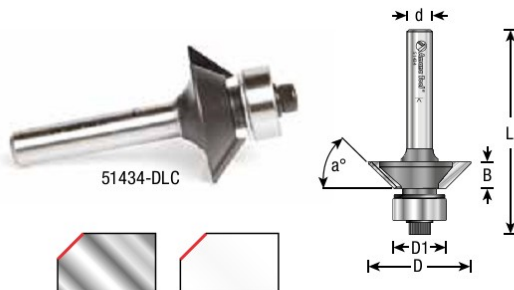

OD	D1	a°	B	Od	L	Tool No.
31/32	1/2	45°	1/4	1/4	1-15/16	51434
31/32	1/2	45°	1/4	1/4	1-15/16	51434-DLC*

* Diamond-Like Carbon (DLC) is a low-friction coating for aluminum and aluminum alloys with a longer tool edge life.

Replacement bearing #47706.

Note: Start at 12,000 RPM, inspect result, and increase the speed for a better surface, if necessary.



INDUSTRIAL 2D/3D Carving CNC Router Bits

Solid Carbide • 2, 3 & 4 Flute • Ball Nose • Tapered and Straight • Up-Cut

Specially designed for 2D and 3D CNC profiling and carving with CNC machines. The high-shear ball nose tips cut smooth 2D and 3D contours with reduced stepping while the optimized flute geometry and low Total Indicated Runout (TIR) guarantees clean cuts, essentially eliminates sanding and reduces chatter. The high flute volume supports high feed rates and chip loads while the high aspect ratio is excellent for single pass, deep-reach cutting. Manufactured with high balance which allows tools to be run up to 60,000 RPMs. Adjust your chip load and feed rate accordingly.

Applications:

- A perfect router bit for 3D carving
- Precision 2D and 3D large scale carving
- Dimensional signage & 3D millwork
- 2D/3D contouring, profiling, modeling & pattern making
- Cabinetry, furniture making
- Jewelry mold making



ØD	B	a°	R	Flute	Ød	L	Uncoated		ZrN Coated	
							Tool No.	Tool No.	Tool No.	Tool No.
1/32	0.445	6.2°	1/64	3	1/8	3	—	46291 †	—	—
1/32	1	6.2°	1/64	3	1/4	2-1/4	—	46280-S	—	—
1/32	1	6.2°	1/64	3	1/4	3	46280-U	46280	—	—
1/32	1-1/2	6.2°	1/64	3	3/8	3-1/2	—	46580	—	—
1mm	1-7/64	5.4°	0.5mm	2	1/4	2-23/64	—	46256	—	—
1/16	0.362	5.4°	1/32	4	1/8	3	—	46293 †	—	—
1/16	1	5.5°	1/32	2	1/4	2-1/4	—	46252-S	—	—
1/16	1	5.5°	1/32	2	1/4	2-23/64	—	46252	—	—
1/16	1	5.4°	1/32	4	1/4	3	46282-U	46282	—	—
1/16	1-1/2	3.6°	1/32	3	1/4	3	—	46281	—	—
1/16	1-1/2	5.4°	1/32	4	3/8	3-1/2	—	46582	—	—
1/8	1/2	7°	1/16	3	1/4	3	—	46288	—	—
1/8	3/4	5°	1/16	3	1/4	3	—	46287	—	—
1/8	1	3.6°	1/16	3	1/4	2-1/4	—	46286-S	—	—
1/8	1	3.6°	1/16	3	1/4	3	46286-U	46286	—	—
1/8	1	3.6°	1/16	4	1/4	3	—	46583	—	—
1/8	1-1/2	0.10°	1/16	3	1/8	3	—	46295 †	—	—
1/8	1-1/2	1°	1/16	3	1/4	3	46284-U	46284	—	—
3/16	1	1°	3/32	3	1/4	3	—	46298	—	—
1/4	1	0.10°	1/8	2	1/4	2-1/4	—	46294-S	—	—
1/4	1	0.10°	1/8	4	1/4	3	—	46584	—	—
1/4	1	7°	1/8	2	1/2	4	—	46289	—	—
1/4	1-1/2	0.10°	1/8	2	1/4	3	46294-U	46294	—	—
1/4	1-3/8	5°	1/8	2	1/2	4	—	46285	—	—
1/4	2	3°	1/8	2	1/2	4	—	46283	—	—
3/8	2-1/4	0.10°	3/16	3	3/8	4	—	46494	—	—
1/2	2-1/4	0.10°	1/4	3	1/2	4	—	46495	—	—

† Router collet reducer RB-102 (1/4 to 1/8) available for 1/8 shank bits.

Packs	Includes	Tool No.	5-Packs	Includes	Tool No.
	46282, 46284 & 46294	AMS-142	46280 (5 Pcs. each)	46280-5	
	46280, 46282 & 46286	AMS-144	46282 (5 Pcs. each)	46282-5	
	46280, 46282 & 46294	AMS-185 <i>New</i>	46284 (5 Pcs. each)	46284-5	
	46282, 46286 & 46294	AMS-146	46286 (5 Pcs. each)	46286-5	
	46256, 46252 & 46254	AMS-110	46294 (5 Pcs. each)	46294-5	
	46290, 46292 & 46294	AMS-145			
	46280, 46282, 46286 & 46294	AMS-148			
	46290, 46292, 46284 & 46288	AMS-141			
	46280-U, 46282-U & 45771	AMS-107 <i>New</i>			

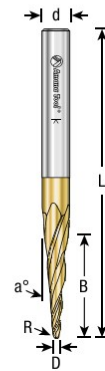

**ZrN
COATED**

Benefits of ZrN Coating:

- Creates a harder and sharper cutting edge
- Allows for a prolonged cutting edge life
- Helps to prevent the build-up of material in the flutes while cutting
- High resistance to wear for faster speeds
- Less friction and heat buildup

Excellent for Cutting:

- Acrylonitrile Butadiene Styrene (ABS)
- Acrylic
- Aluminum
- Brass
- Bronze
- Copper
- Gold
- Silver
- Titanium
- Composite
- Dibond®
- Ethafoam
- Expanded Polypropylene (EPP)
- Fiberglass
- Expanded Polystyrene Foam (EPS)
- Extruded Polystyrene Foam (XPS)
- Foam Board
- Graphite
- 20lbs High Density Urethane
- High Density Polyethylene (HDPE)
- High Density Urethane (HDU)
- Lexan™
- MDF/HDF
- Non-Ferrous Metals
- Phenolics
- Phenolic Composites
- Polyethylene Foam
- Polyam
- Polyurethane Foam
- PVC
- PVC Foam Board
- Sign Board
- Sign Foam
- Tooling Board
- Wood
- XLPE (Cross Linked Polyethylene) Foam

CNC feed and speed available online

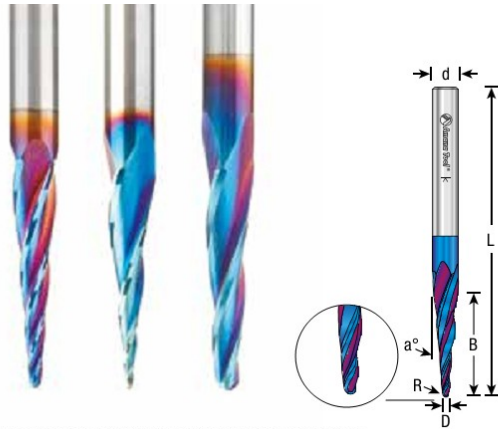

Spektra™ 2D/3D Bits Excellent for Cutting:

- Acrylonitrile Butadiene Styrene (ABS)
- Acrylic
- Acrylic Stone
- Composite
- Corian
- Coroplast®
- Dibond®
- Ethafoam
- Expanded Polypropylene (EPP)
- Ethylene-vinyl Acetate Foam (EVA)
- Expanded Polypropylene (EPP)
- Expanded Polystyrene Foam (EPS)
- Extruded Polystyrene Foam (XPS)
- Fiberglass
- Fiberglass PCB Board
- Foam Board
- Graphite
- 20lbs High Density Urethane
- High Density Polyethylene (HDPE)
- High Density Urethane (HDU)
- Lexan™
- MDF/HDF
- PALFOAM™
- Plastics
- Poly (methyl methacrylate) (PMMA)
- Phenolics
- Phenolic Composites
- Polyethylene Foam
- Polylyam
- Polyurethane Foam
- PVC
- PVC Foam Board
- Sign Board
- Sign Foam
- Tooling Board
- Wood
- XLPE (Cross Linked Polyethylene) Foam



Benefits of Spektra™ Coating:

- Provides longevity and produces cutting results of the highest quality
- Prevents high heat and oxidation
- Impressive solid hardness on cutting areas
- Increased longevity up to 2.5 times compared to uncoated bits

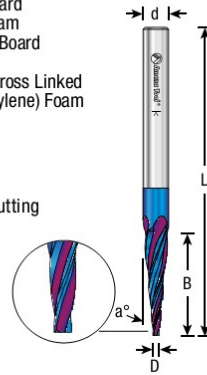

CNC 2D/3D CARVING TAPERED BALL NOSE

Solid Carbide • Ball Nose • Up-Cut

Specially designed for 2D and 3D CNC profiling and carving with CNC machines. Spektra™ bits feature a nACo® nanocomposite coating with an extreme nanohardness and heat resistance.



ØD	B	a°	R	Flute	Ød	L	Tool No.
1/32	1	6.2°	1/64	3	1/4	3	46280-K
1/16	1	5.4°	1/32	4	1/4	3	46282-K
1/8	1/2	7°	1/16	3	1/4	3	46288-K <i>New</i>
1/8	1	3.6°	1/16	3	1/4	3	46286-K
1/8	1-1/2	0.10°	1/16	3	1/8	3	46295-K † <i>New</i>
1/8	1-1/2	1°	1/16	3	1/4	3	46284-K
1/4	1/2	0.10°	1/8	2	1/4	3	46294-K

† Router collet reducer RB-102 (1/4 to 1/8) available for 1/8 shank bits.

Packs <i>New</i>	Includes	Tool No.	5-Packs <i>New</i>	Includes	Tool No.
46282-K, 46284-K & 46294-K	AMS-142-K	46280-K (5 Pcs. each)	46280-K-5		
46280-K, 46282-K & 46286-K	AMS-144-K	46282-K (5 Pcs. each)	46282-K-5		
46282-K, 46286-K & 46294-K	AMS-146-K	46286-K (5 Pcs. each)	46286-K-5		
46280-K, 46282-K,					
46286-K & 46294-K	AMS-148-K				
46282-K & 45624 (60°)	AMS-192				
46280-K, 46282-K & 45771-K	AMS-107-K				



CNC 2D/3D CARVING TAPERED AND STRAIGHT FLAT BOTTOM *New*

Solid Carbide • Flat Bottom • Up-Cut

High-shear flat bottom tips cut smooth 2D and 3D contours with reduced stepping. Spektra™ extreme tool life coated.



ØD	B	a°	Flute	Ød	L	Tool No.
1/16	5/16	0.10°	3	1/4	2	46290-K
1/8	1-3/32	0.10°	4	1/4	2-1/2	46292-K
1/4	1-1/2	0.10°	2	1/4	3	46577-K



CNC 2D/3D CARVING TAPERED AND STRAIGHT FLAT BOTTOM

Solid Carbide • Flat Bottom • Up-Cut

High-shear flat bottom tips cut smooth 2D and 3D contours with reduced stepping. ZrN coated. For material cut list visit www.amanatool.com.



ØD	B	a°	Flute	Ød	L	Uncoated	ZrN Coated
						Tool No.	Tool No.
1/32	0.445	6.2°	3	1/8	3	—	46571 †
1/32	1	6.2°	3	1/4	3	—	46570
1/16	5/16	0.10°	3	1/4	2	46290-U	46290
1/16	1	5.4°	4	1/4	3	—	46572
1/8	15/32	0.10°	2	1/4	2-23/64	—	46254
1/8	1/2	7°	3	1/4	3	—	46576
1/8	1	3.6°	3	1/4	3	—	46573
1/8	1-3/32	0.10°	4	1/4	2-1/2	46292-U	46292
1/8	1-1/2	0.10°	3	1/8	3	—	46299
1/8	1-1/2	1°	3	1/4	3	—	46574
3/16	1	1°	3	1/4	3	—	46575
1/4	3/4	0.10°	3	1/4	2-1/2	—	46578 <i>New</i>
1/4	1-1/2	0.10°	2	1/4	3	—	46577
3/8	1-3/4	0.10°	3	3/8	3	—	46597 <i>New</i>
1/2	2-1/4	0.10°	3	1/2	4	—	46579

† Router collet reducer RB-102 (1/4 to 1/8) available for 1/8 shank bits.



CNC feed and speed available online



CNC METRIC 2D/3D CARVING TAPERED AND STRAIGHT

Solid Carbide • Ball Nose (Conical Ball) • Up-Cut



ØD	B	a°	R	Flute	Ød	L	Tool No.
0.5mm	26.5mm	6.2°	0.25mm	3	6mm	75mm	46473 New
0.8mm	25mm	6.2°	0.40mm	3	6mm	75mm	46470
1mm	3mm	0.10°	.019	3	1/8	1-1/2	46471
1.5mm	25mm	5.4°	0.75mm	4	6mm	75mm	46472
3.2mm	38mm	1°	1.6mm	3	6mm	75mm	46474
6.0mm	38mm	0.10°	3.0mm	2	6mm	75mm	46479

Solid Carbide • Flat Bottom (Square End) • Up-Cut

ØD	B	a°	Flute	Ød	L	Tool No.
1mm	3mm	0.10°	3	1/8	1-1/2	46581 †
6mm	38mm	0.10°	2	6mm	75mm	46585

† Router collet reducer RB-102 (1/4 to 1/8) available for 1/8 shank bits.

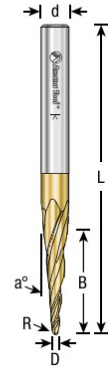

Ball Nose



Flat Bottom



CNC EXTRA-LONG REACH 2D/3D CARVING FLAT BOTTOM AND BALL NOSE

Solid Carbide with Reduced Shank • 3 Flute • Up-Cut

Extra-long reduced shank section for deeper reach and better chip clearance.

The industrial router bits can be used in sign making & 3D Carving industries in MDF, Plastics, Bronze, Copper, Aluminum, Foam, Wood and other materials. The simultaneous 3-axis motion with the appropriate software allows full 3D capability that provides sign and 3D model makers the ability to work with most materials.



Ball Nose (Conical Ball)

ØD	B	a°	R	Ød	Ød1	L	L1	Tool No.
1/4	1/2	0.10°	1/8	1/4	15/64 (.235)	4	1-1/4	46490
3/8	3/4	0.10°	3/16	3/8	23/64 (.352)	4	1-1/4	46491
1/2	1	0.10°	1/4	1/2	15/32 (.470)	6	1-1/2	46493
1/2	1-1/4	0.10°	1/4	1/2	15/32 (.470)	7	2	46496

Flat Bottom (Square End)

ØD	B	a°	Ød	Ød1	L	L1	Tool No.
1/4	1/2	0.10°	1/4	15/64 (.235)	4	1-1/4	46590
3/8	3/4	0.10°	3/8	23/64 (.352)	4	1-1/4	46591 New
1/2	1	0.10°	1/2	15/32 (.470)	6	1-1/2	46593
1/2	1-1/4	0.10°	1/2	15/32 (.470)	7	2	46596

Tools are manufactured with high balance, that allows them to run up to 60,000 RPM. Adjust your chip load and feed rate accordingly.



CNC feed and speed available online



CNC EXTRA-LONG REACH 2D/3D CARVING FLAT BOTTOM AND BALL NOSE **New**

Solid Carbide with Reduced Shank • 3 Flute • Ball Nose (Conical Ball)

Extra-long reduced shank section for deeper reach and better chip clearance.

For complete details on Spektra™ visit www.amanatool.com/spektra



ØD	B	a°	R	Ød	Ød1	L	L1	Tool No.
1/4	1/2	0.10°	1/8	1/4	15/64 (.235)	4	1-1/4	46490-K

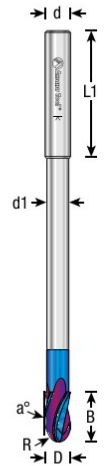
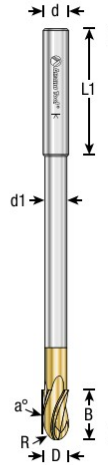

For material cut list visit www.amanatool.com.

ZrN Coated Excellent for Cutting:

- Acrylonitrile Butadiene Styrene (ABS)
- Acrylic
- Aluminum
- Brass
- Bronze
- Copper
- Gold
- Silver
- Titanium
- Composite
- Dibond®
- Ethafoam
- Expanded Polypropylene (EPP)
- Fiberglass
- Expanded Polystyrene Foam (EPS)
- Extruded Polystyrene Foam (XPS)
- Foam Board
- Graphite
- 20lbs High Density Urethane
- High Density Polyethylene (HDPE)
- High Density Urethane (HDU)
- Lexan™
- MDF/HDF
- Non-Ferrous Metals
- Phenolics
- Phenolic Composites
- Polyethylene Foam
- Polylyam
- Polyurethane Foam
- PVC
- PVC Foam Board
- Sign Board
- Sign Foam
- Tooling Board
- Wood
- XLPE (Cross Linked Polyethylene) Foam

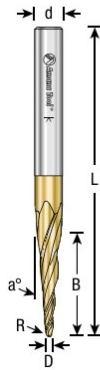

CNC 2D/3D CARVING HIGH SPEED STEEL (HSS) TAPERED AND STRAIGHT New

High Speed Steel (HSS) • 3 & 4 Flute • Up-Cut

Specially designed for 2D/3D CNC profiling and carving in plastic, aluminum & wood with CNC machines. High-shear ball nose tips cut smooth 2D and 3D contours with reduced stepping. ZrN Coated.



Applications:

- A perfect router bit for 3D carving
- Precision 2D and 3D large scale carving
- Dimensional signage & 3D millwork
- 2D/3D contouring, profiling, modeling & pattern making
- Cabinetry, furniture making
- Jewelry mold making

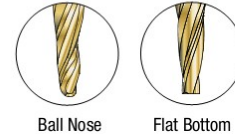

Ball Nose

ØD	B	a°	R	Flute	Ød	L	Tool No.
1/32	1	6.2°	1/64	3	1/4	3	HSS1300
1/16	1	5.4°	1/32	4	1/4	3	HSS1302
1/8	1	3.6°	1/16	3	1/4	3	HSS1304
1/8	1-1/2	1°	1/16	3	1/4	3	HSS1306

Flat Bottom (Square End)

ØD	B	a°	Flute	Ød	L	Tool No.
1/16	5/16	0.10°	3	1/4	2	HSS1310
1/8	1-3/32	0.10°	4	1/4	2-1/2	HSS1312



1/4" SHANK

Set #AMS-136 Includes:

46280, 46282, 46284, 46286, 46288, 46294, 46290 & 46292



8-PC CNC 2D/3D CARVING

1/4" Shank • Solid Carbide Spiral Ball Nose and Flat Bottom Router Bit Collection • Up-Cut

Designed for 2D and 3D CNC profiling and carving. See below table for material cut list.



1/8" SHANK

1/4" SHANK

Set #AMS-143 Includes:

46280, 46282, 46284, 46286, 46288, 46294, 46292, 46291, 46295, 46287, 46570, 46572, 46574, 46490, 46590, 46094, 46090 & RB-102 (2)



18-PC. CNC 2D/3D CARVING & LETTERING

1/8" & 1/4" Shank • Solid Carbide Router Bit Collection • Up-Cut

Designed specifically for precision 2D and 3D applications.

AMS-136 and AMS-143 Excellent For Cutting:

- Acrylonitrile Butadiene Styrene (ABS)
- Acrylic
- Aluminum
- Aluminum Alloys
- ACM
- Alucobond®
- Alupanel®
- Brass/Bronze
- Carbon Fiber
- CCM
- Composites
- Copper
- Dibond®
- Expanded Polystyrene Foam (EPS)
- Extruded Polystyrene Foam (XPS)
- Fiberglass
- Fiberglass PCB Board
- Graphite
- HDF/MDF
- HDPE
- HDU
- Lexan™
- Non-Ferrous Metals
- Phenolics
- Phenolic Composites
- Plastic/Acrylic
- Plywood
- PVC
- Silver/Gold
- Sign Foam
- TCM
- Titanium
- Tooling Board
- Wood
- 20lbs High Density Urethane
- XPE





NON-FERROUS METAL

6° Negative Hook • Triple Chip (TC) Grind

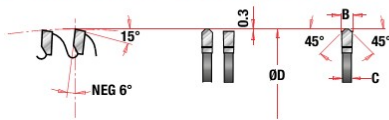

Ideal for cutting aluminum and non-ferrous metal bars such as copper, brass, bronze and lead. It also is good for cutting extrusions and profiles. The negative hook angle (-6°), triple-chip grind and thick plate combine to produce a superior finish. The blade can also be used to cut other "difficult" materials such as plastic, PVC tubing, fiberglass and ACM such as Alucobond®, Dibond® and Durabond®. Use a coolant or blade wax and clamp down the work-piece when cutting non-ferrous metals.



For Thick Aluminum (over 0.25")

ØD Inch	ØD mm	Teeth	Grind	'B' Kerf Inch	'C' Plate Inch	Bore	*P.H.	ACM	Non-Ferrous Alloys	Phenolic & Hard Plastic	Tool No.
8	200	48	TCG	.110	.087	5/8	—				584801
10	250	60	TCG	.126	.102	5/8	—				510601
10	250	60	TCG	.126	.102	30mm	2/7/42, 2/9/46 & 2/10/60				510601-30
12	300	72	TCG	.126	.102	1	—				512721
12	300	72	TCG	.126	.102	30mm	2/7/42, 2/9/46 & 2/10/60				512721-30
14	350	84	TCG	.126	.102	1	—				514841
16	400	96	TCG	.150	.126	1	—				516961
18	450	108	TCG	.157	.134	1	—				518108

For Thin Material (under 0.25")

ØD Inch	ØD mm	Teeth	Grind	'B' Kerf Inch	'C' Plate Inch	Bore	*P.H.	Machines	Tool No.
7	180	58	TCG	.110	.087	5/8	—		575601
8	200	64	TCG	.110	.087	5/8	—		586401
9	230	60	TCG	.110	.087	5/8	—		596001
10	250	80	TCG	.126	.102	5/8	—		510801
10	250	80	TCG	.126	.102	5/8	—		510801C *
10	250	80	TCG	.126	.102	30mm	2/7/42, 2/9/46 & 2/10/60		510801-30
10	250	100	TCG	.126	.102	5/8	—		510101
12	300	96	TCG	.126	.102	1	—		512961
12	300	96	TCG	.126	.102	30mm	2/7/42, 2/9/46 & 2/10/60		512961-30
14	350	100	TCG	.146	.118	5/8	—	Pistorious	514101-5/8HD
14	350	108	TCG	.126	.102	1	—		514108
14	350	108	TCG	.126	.102	30mm	2/7/42, 2/9/46 & 2/10/60		514108-30
15	375	100	TCG	.120	.098	1	—	Hitachi	515101 †
16	400	120	TCG	.150	.126	1	—		516121
18	450	120	TCG	.150	.126	1	—		518121
20	500	120	TCG	.174	.140	1	—		520121
20	500	120	TCG	.174	.156	30mm	2/7/42, 2/9/46 & 2/10/60		520121-30

† For Hitachi Miter box (Thin Kerf).

WARNING: Never attempt to cut ferrous metals (steel, iron, etc.) with the saw blades on this page.

* Electro Blu™ Non-Stick Coating.

* P.H. denotes pin-hole configuration, if applicable.

Example: 2/10/60 = 2 @ 10mm dia. on 60mm circle.

▲ Warning: Before use, read saw blade safety guidelines on pages 344-346.

INDUSTRIAL SAW BLADES

323